

MODULAR SOLUTIONS SUMMIT BILBAO



Liderando la construcción industrializada,
circular y certificada

12 DE JUNIO / 10:30H - 13:30H

PORCELANOSA Bilbao,
Plaza Euskadi, 2
(Bilbao)

PORCELANOSA
Bilbao

Organiza:



PRE FAB

The innovation behind.

Industrializar también la instalación eléctrica:
eficiencia, seguridad y sostenibilidad.

La evolución hacia sistemas **plug&play** y **prefabricados** que transforman la manera de proyectar y ejecutar edificios

EXPERTOS EN CONEXIONADO ELÉCTRICO



Multinacional alemana

14 filiales en todo el mundo

+ 25 años en el mercado español

Diseño y fabricación

de conexiones eléctricas desde 1910

+ de 25.000 referencias

Desarrollo de conceptos innovadores de conexionado

para la instalación eléctrica enchufable
en la Edificación y la Industria

EVOLUCIÓN DE LA INSTALACIÓN ELÉCTRICA ENCHUFABLE



1910
LA PRIMERA BORNA



1965

Primer terminal de regleta con pines de contacto para crear una conexión enchufable



1973

Wieland patenta el primer sistema de conector industrializado



1990

Primer sistema de instalación enchufable completo © GESIS GST18



2009

Norma Internacional IEC EUROPEA EN 61535

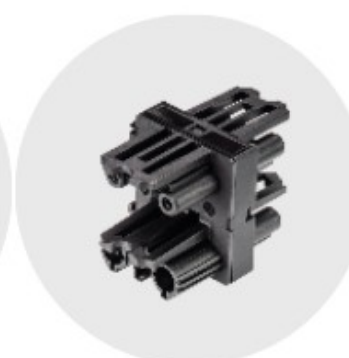

2010

Norma española UNE EN 61535 sobre: Conectores de instalación previstos para conexión permanente en instalaciones fijas.



ACTUALMENTE

> 4.000.000.000 CONTACTOS GESIS EN USO
> 50.000.000 m CABLES PRE-ENSAMBLADOS INSTALADOS

SOLUCIONES ENCHUFABLES VS INSTALACIÓN ELÉCTRICA CONVENCIONAL



- ⚠ Alto contenido de mano de obra
- ⚠ Gran consumo de tiempo
- ⚠ Necesidad de personal cualificado
- ⚠ Gran cantidad de “mermas” y residuos
- ⚠ Alta posibilidad de fallos
- ⚠ Dificultad para asegurar la calidad
- ⚠ Poca planificación
- ⚠ Bajo nivel de innovación
- ⚠ Poco sostenible ni ecológica
- ⚠ Poco flexible para ampliaciones y mantenimientos



- ✅ Instalación más flexible, sostenible y eficiente.
- ✅ Aporta valor e innovación al proyecto arquitectónico y a las certificaciones.
- ✅ Sistema totalmente prefabricado, mismo concepto de la construcción industrializada.



► Instalación convencional:
corta, desforra, emborna y atornilla

Instalación enchufable:
► 1 click, y listo!

VENTAJAS DE LA INSTALACIÓN ELÉCTRICA **PLUG&PLAY**

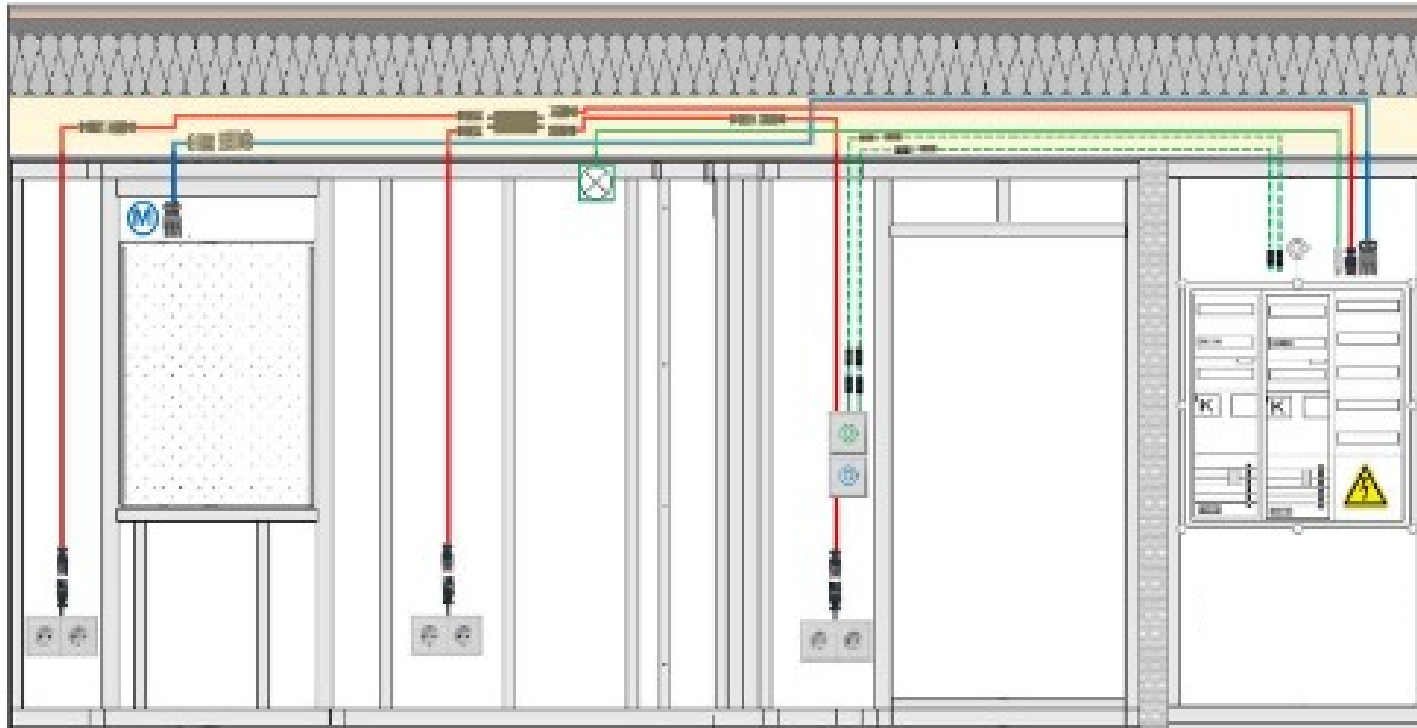

AHORRO Y RAPIDEZ

Reducción 70% tiempo instalación
Reducción hasta 30% costes instalación

SEGURIDAD

Sin errores de conexión
Seguridad frente a riesgo eléctrico

FACILIDAD Y FLEXIBILIDAD

Instalación y mantenimiento
Ante modificaciones y adaptaciones

CALIDAD

Instalación certificada ISO9001
Incremento del valor añadido

SOSTENIBILIDAD

100% reutilizable
0% desperdicio

COMPONENTES DE LA INSTALACIÓN ELÉCTRICA **PLUG&PLAY**



► **Conectores**



► **Cables**



► **Derivadores y cajas distribuidoras**



► **Conectores para equipos**

INSTALACIÓN INNOVADORA ...



... enchufar y funcionar

COMPONENTES DE LA INSTALACIÓN ELÉCTRICA **PLUG&PLAY ESTANCA**



 **wieland**



► **Conectores**



► **Cables**



► **Derivadores**



► **Conectores para equipos**

INSTALACIÓN INNOVADORA ...



... enchufar y funcionar

VENTAJAS SOSTENIBLES DE LA INSTALACIÓN ELÉCTRICA PLUG&PLAY



Desarrollo / producción con un claro enfoque a la calidad y función duraderas

Conceptos para la reducción de longitud de los cables y aumentar la flexibilidad

Recursos adicionales reducidos

Desinstalar / Reciclar

Proyecto / Instalación

Minimización de residuos en caso de cambios / ampliaciones

Cambio de uso / Renovación

Uso / Mantenimiento

Flexibilidad permanente de la instalación eléctrica en caso de nuevos requisitos

Esfuerzo reducido al reemplazar o ampliar instalaciones

▶ ECONOMÍA CIRCULAR

Todos los componentes de la instalación eléctrica son 100% reciclables y reutilizables.

Aumenta el ciclo de vida de la instalación.

Dispone de calidad certificada ISO9001 al ser montada y testeada en fábrica.

Mejora las valoraciones en certificaciones de sostenibilidad del edificio: BREAM®, LEED®, WELL®.

Reduce la huella de carbono.

CERTIFICACIONES DE DISEÑO SOSTENIBLE



DGNB Checklist				
Main Criteria Group	Criteria Group	No.	Criterion	max. Weighting (Group)
Impacts on global and local environment		1	Global warming potential	10
		2	Ozone depletion potential	10
		3	Photochemical ozone creation potential	10
		4	Acidification potential	10
		5	Eutrophication potential	10
Energy Quality		6	Risks to the regional environment	10
		7	Other impacts on the global environment	10
		8	Microclimate	10
		9	Non-renewable primary energy demand	10
		10	Total primary energy demand and recovery of renewable primary energy	10
Utilization of resources and waste saving		11	Water consumption and wastewater treatment	10
		12	Protable water consumption and sewage generation	10
		13	Surface area usage	10
		14	Building-related life cycle costs	10
		15	Value stability	10
Environmental Quality		16	Building-related life cycle costs	10
		17	Value stability	10
		18	Thermal comfort in the winter	10
		19	Thermal comfort in the summer	10
		20	Indoor Hygiene	10
Performance, Health, comfort and user satisfaction		21	Acoustic comfort	10
		22	Visual Comfort	10
		23	Indoor air quality	10
		24	Roof design	10
		25	Safety and risks of failure	10
Accessibility and Functional Quality		26	Safety and risks of failure	10
		27	Area efficiency	10
		28	Accessibility of circulation	10
		29	Accessibility	10
		30	Bioclimatic comfort	10
Quality of the building		31	Assessment of quality of design and for urban development for competition	10
		32	Air/water/soil protection	10
		33	Fire protection	10
		34	Noise protection	10
		35	Energy use and building footprint	10
Functional Quality		36	Case of Changing and Maintenance of the structure	10
		37	Ease of deconstruction, recycling and d	10
		38	Quality of the project's preparation	10
		39	Integrated planning	10
		40	Optimization and complexity of the app	10
Quality of the planning		41	Evidence of sustainability consideration	10
		42	Establishment of procedures for apps	10
		43	Construction site, construction phase	10
		44	Quality of existing companies, pre-conditions	10
		45	Quality assurance of the construction	10
Quality of the construction activities		46	Systemic commissioning	10
		47	Risks of the construction	10
		48	Circumstances at the construction	10
		49	Terms and conditions of the location and neighborhood	10
		50	Connection to transportation	10
Quality of the location		51	Proximity to usage-specific facilities	10
		52	Adapting needs, infrastructure development	10
		53	Proximity to usage-specific facilities	10
		54	Adapting needs, infrastructure development	10
		55	Proximity to usage-specific facilities	10

BREEAM Checklist				
Management				
Man 1	Commissioning	2	2.18 %	
Man 2	Responsible contractors	2	2.18 %	
Man 3	Impact of the construction site	4	4.36 %	
Man 4	User Manual	1	1.00 %	
Man 12	Life cycle cost calculation	2	2.18 %	
Health & Wellbeing				
Hea 1	Daylighting	1	1.07 %	
Hea 2	Views	1	1.07 %	
Hea 3	Glare shield	1	1.07 %	
Hea 4	Visual acuity design	1	1.07 %	
Hea 5	Internal and external illuminance	1	1.07 %	
Hea 6	Zonal controllability of lighting	1	1.07 %	
Hea 7	Natural ventilation	1	1.07 %	
Hea 8	Indoor air quality	1	1.07 %	
Hea 9	Volatle organic compounds (VOC)	1	1.07 %	
Hea 10	Thermal comfort	2	2.14 %	
Hea 11	Zonal controllability of room temperature	1	1.07 %	
Hea 12	Microbiological load (Legionella)	1	1.07 %	
Hea 13	Soundproofing	1	1.07 %	
Energy				
Ena 1	Energy efficiency	15	11.87 %	
Ena 2	Measuring devices for large energy consumers	1	0.79 %	
Ena 3	Thermal energy consumption measurement	1	0.79 %	
Ena 4	Outdoor lighting	1	0.79 %	
Ena 5	Renewable energy	3	2.38 %	
Ena 8	(energy-saving) lifts	2	1.58 %	
Ena 9	Moving walkways and escalators	1	0.79 %	
Transport				
Tran 1	Public transport	2	1.58 %	
Tran 2	Distance to utilities	1	0.79 %	
Tran 3	Alternative private transport	2	1.58 %	
Tran 4	Safety for pedestrians and cyclists	1	0.79 %	
Tran 5	Routing plan for the building users	1	0.79 %	
Tran 6	Maximum parking capacity	2	1.58 %	
Water				
Wat 1	Water consumption	3	2.38 %	
Wat 2	Water consumption measurement	1	0.79 %	
Wat 3	Detection of leaks in the system	1	0.79 %	
Wat 4	Disinfecting means of sanitary areas	1	0.79 %	
Wat 6	Irrigation systems	1	0.79 %	
Wat 8	Water purification systems	2	1.58 %	
Materials				
Mat 1	Building Materials	4	3.05 %	
Mat 2	Surface materials and enclosures	1	0.79 %	
Mat 3	Re-use of facade elements	1	0.79 %	
Mat 4	Re-use of supporting construction elements	1	0.79 %	
Mat 5	sustainable building materials recovery	3	2.38 %	
Mat 6	Thermal insulation	2	1.58 %	
Mat 7	Resistance to water	1	0.79 %	
Waste				
Wst 1	Waste management on site	3	2.31 %	
Wst 2	Recycled materials	1	1.07 %	
Wst 3	Storage of recyclable waste	1	1.07 %	
Wst 4	Treatment of organic waste - composting	1	1.07 %	
Wst 5	Avoid temporary flooring	1	1.07 %	
Land Use & Ecology				
LE 1	Land use	1	1.00 %	
LE 2	Soil contamination	1	1.00 %	
LE 3	Protection of ecological peculiarities of the land	1	1.00 %	
LE 4	Impact on ecology of the site	2	2.00 %	
LE 6	Long-term impact on biodiversity	2	2.00 %	
Religion				
Rel 1	Building amination potential of the refrigerant	1	0.83 %	
Rel 2	Avoid leaks in refrigeration equipment	2	1.67 %	
Rel 4	NO _x emissions from heating systems	3	2.50 %	
Rel 5	Flooding risk	2	1.67 %	
Rel 6	Minimize the contamination of surface water	1	0.83 %	
Rel 7	Reduction of light pollution at night	1	0.83 %	
Rel 8	Reduction of noise emissions	1	0.83 %	
Innovation				
Inn 1	Innovations (1 point for each innovation, max. 10 point)	10	10.00 %	

LEED Checklist				
Sustainable Sites				
P 1	Construction Activity Pollution Prevention	R		
C 1	Site Selection	1		
C 2	Development Density and Community Connectivity	5		
C 3	Brownfield Redevelopment	1		
C 4.1	Alternative Transportation - Public Transportation Access	6		
C 4.2	Alternative Transportation - Bicycle Storage and Changing Rooms	1		
C 4.3	Alternative Transportation - Low-Emitting and Fuel-Efficient Vehicle	3		
C 4.4	Alternative Transportation - Parking Capacity	2		
C 5.1	Site Development - Protect or Restore Habitat	1		
C 5.2	Site Development - Maximize Open Space	1		
C 6.1	Stormwater Design - Quantity Control	1		
C 6.2	Stormwater Design - Quality Control	1		
C 7.1	Heat Island Effect - Non-roof	1		
C 7.2	Heat Island Effect - Roof	1		
C 8	Light Pollution Reduction	1		
Water Efficiency				
P 1	Water Use Reduction - 20% Reduction	R		
C 1.1	Water Efficient Landscaping - Reduce by 50%	2		
C 1.2	Water Efficient Landscaping - No Potable Water Use or Irrigation	2		
C 2	Innovative Wastewater Technologies	4		
C 3	Water Use Reduction	4		
Energy & Atmosphere				
P 1	Fundamental Commissioning of Building Energy Systems	R		
P 2	Minimum Energy Performance	R		
P 3	Fundamental Refrigerant Management	R		
C 1	Optimize Energy Performance	15		
C 2	Onsite Renewable Energy	7		
C 3	Enhanced Commissioning	2		
C 4	Enhanced Refrigerant Management	2		
C 5	Measurement and Verification	3		
C 6	Green Power	2		
Materials & Resources				
P 1	Storage and Collection of Recyclables	R		
C 1.1	Building Reuse - Maintain Existing Walls, Floors and Roof	3		
C 1.2	Building Reuse - Maintain 50% of Interior Non-Structural Elements	1		
C 2	Construction Waste Management	2		
C 3	Materials Reuse	2		
C 4	Recycled Content	2		
C 5.1	Regional Materials	2		
C 6	Rapidly Renewable Materials	1		
C 7	Certified Wood	1		
Indoor Environmental Quality				
P 1	Minimum Indoor Air Quality Performance	R		
P 2	Environmental Tobacco Smoke (ETS) Control	R		
C 1	Outdoor Air Delivery Monitoring	1		
C 2	Increased Ventilation	1		
C 3.1	Construction IAQ Management Plan - During Construction	1		
C 3.2	Construction IAQ Management Plan - Before Occupancy	1		
C 4.1	Low-Emitting Materials - Adhesives and Sealants	1		
C 4.2	Low-Emitting Materials - Paints and Coatings	1		
C 4.3	Low-Emitting Materials - Flooring Systems	1		
C 4.4	Low-Emitting Materials - Composite Wood and Agrifiber Products	1		
C 5	Indoor Chemical and Pollutant Source Control	1		
C 6.1	Controllability of Systems - Lighting	1		
C 6.2	Controllability of Systems - Thermal Comfort	1		
C 7.1	Thermal Comfort - Design	1		
C 7.2	Thermal Comfort - Verification	1		
C 8.1	Daylight and Views - Daylight	1		
C 8.2	Daylight and Views - Views	1		
Innovation and Design Process				
C 1	Innovation In Design	5		
C 2	LEED Accredited Professional	1		
Regional Priority Credits				
C 1	Regional Priority	4		

- + Reducción de materiales y recursos.
- + Facilidad de deconstrucción y reciclaje.
- + Reducción de residuos.
- + Reutilización de materiales.
- + Costos del ciclo de vida de la construcción.
- + Facilidad de mantenimiento y/o renovación.
- + Innovación en materiales y diseño.
- + Calidad de procesos.
- + Aseguramiento de la calidad de la construcción.
- + Rendimiento energético en la fabricación.

SEGURIDAD ESTANDARIZADA Y CALIDAD DEMOSTRADA



EN 61535



▼
Cumple con las normativas.

Sin mantenimiento.

Calidad asegurada “made in Germany”.

Productos y procedimientos testados por normativas estándar IEC/EN.

Aplicación en el mercado en proyectos desde hace más de 30 años.

ESPACIOS DE INSTALACIÓN



▼
Falsos techos

Suelos técnicos o entarimado

Paredes

Aperturas prefabricadas en pared y perfiles para las instalaciones de los mecanismos.

Sistemas de conducción de cableado o canales.

APLICACIONES EN LA CONSTRUCCIÓN PREFABRICADA



WIELAND **PRE
FAB**®

The innovation behind.



▶ **CONSTRUCCIÓN MODULAR
INDUSTRIALIZADA**

EN MADERA

EN HORMIGÓN

EN SECO

EN ACERO

CONSTRUCCIÓN PREFABRICADA EN MADERA



Se aprovechan los huecos de la construcción para optimizar el trazado y ocultamiento de los elementos de la instalación eléctrica.

La alta seguridad y fiabilidad de las conexiones prefabricadas disminuye el riesgo por fallo eléctrico.

No son necesarios ni tubos ni cajas de conexión.

No es necesario personal con un alto nivel de formación eléctrica para la implementación de la instalación.

CONSTRUCCIÓN PREFABRICADA EN HORMIGÓN



Sistema de conexión enchufable con grado de protección IP69 RST® CLASSIC.

Las conexiones eléctricas prefabricadas estancas permiten incluir las instalaciones en el proceso de fabricación de los paramentos (paredes, techos, etc..).

La estanqueidad de la instalación se asegura durante todo el ciclo de vida de la instalación, desde la fabricación, al montaje y el uso.

CONSTRUCCIÓN PREFABRICADA EN ACERO

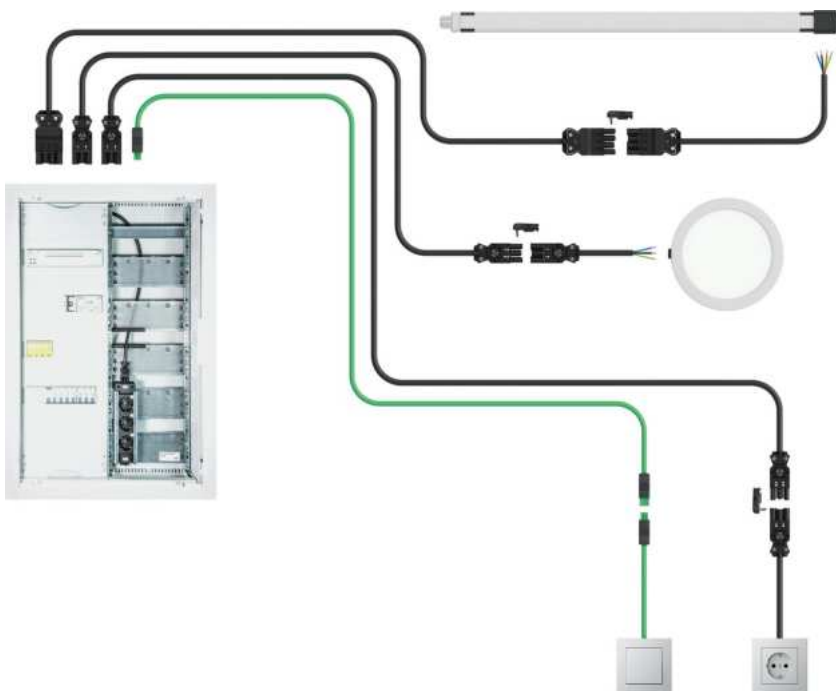

Se utiliza la propia estructura como canalización para la conducción de la instalación eléctrica.

La perfilería metálica puede alojar tanto el cableado (aislamiento 06/1kV) como los distribuidores (aislamiento 1000V y grado IP40).

La instalación eléctrica puede venir ya alojada en los tramos prefabricados y en el montaje sólo se tienen que enchufar entre ellos.

CONSTRUCCIÓN PREFABRICADA EN SECO



Se aprovechan los huecos de la construcción para optimizar el trazado y ocultamiento de los elementos de la instalación eléctrica.

Los mecanismos eléctricos (enchufes, interruptores, etc...) pueden venir preinstalados en los cerramientos o pueden ser instalados de forma sencilla plug&play en obra para permitir una personalización de los acabados

No son necesarios ni tubos ni cajas de conexión.

PROYECTOS REALIZADOS



Hangares modulares
en Woensdrecht (países bajos)

Setas Sevilla
Estructura modular de madera

Pabellones prefabricados
en la Antártida

Casas prefabricadas WOLF

Salas y cabinas insonorizadas

Puente de Budapest

PRE
FAB

The innovation behind.



CONTACTO

Email: info.spain@wieland-electric.com

Teléfono: +34 93 252 38 20

Web: www.wieland-Electric.es

Ecatalogue: Eshop.wieland-electric.com

Linkedin: [Linkedin.WielandElectric.España](https://www.linkedin.com/company/WielandElectric.España)

<https://www.wieland-electric.com/en/home/prefab/>